



NITECH IPM[®]
NITECH INTERNATIONAL PACKAGING MACHINES

MillerBevco.com
Info@MillerBevco.com

LP20/20 UTS Stretch Wrapper

Low Maintenance
4-Year Warranty

Dual Chain Film Elevator
1/2 hp Variable Speed DC
Gearmotor with UHMW
Polyethylene Slide Bearing

- Micro-Computer Control
- Touch Keypad for Programming
- Industrial Push Buttons for Operating

Photo Electric
Load Height
Sensor

Heavy-Duty
Formed Steel
Tower

Quick-Threading
Uni-Tension Power
Pre-Stretch System Accepts
20" and 30" Wide Film
1/2 hp Variable Speed
DC Motor

Fork-Lift Tubes
For Portability

★ MADE IN THE USA ★



Turntable Powered with
Non-Stretch Non-Jamming Belt
Drive 3/4hp Variable Speed DC
Gearmotor 0-15 rpm

60" Round Turntable, 3" Table Height
6,000 lbs. Capacity

Optional Loading
Ramp Available

Operates on 115 Volts, 50/60HZ

The Heavy Duty LP20/20 UTS Semi-Automatic Stretch Wrapper is made to meet the requirements of today's demanding market.

Miller/Bevco
6209 Richards Dr.
Shawnee, Kansas 66216

1-800-821-2177

Ph: 913-322-6800
Fax: 913-322-1729
Miller/Bevco.com

© Copyright 2013 NitechIPM. All Rights Reserved. Specifications, design, accessories or pricing without notice. Artwork does not indicate model or year and may only be reproduced with written permission from NitechIPM

SPECIFICATIONS



TOWER DESIGN

The heavy-duty 10 gauge formed steel tower provides ruggedness and stability. The film carriage elevator uses maintenance-free UHMW polyethylene slides that require no lubrication. Concealed within the tower is a dual roller chain elevator that provides proven strength, reliability and positive drive. The rear door of tower accesses elevator drive and electrical control panel.

ALTERNATE ROLLER-BRAKE (RBM)

In addition to our pre-stretch systems, the LP2020 is also available with Roller-Brake. The Roller-Brake uses a magnetic particle brake on a urethane roller to provide constant tension for wrapping with stretch film, vented film or plastic netting. An optional attachment enables banding or film roping.

The unique HI-SLIDE telescoping mast (left) enables wrapping loads up to 130" tall. The built-in telescoping mast eliminates field installation of extended mast structures and allows the LP2020 to be shipped completely assembled.



RETROFIT OPTIONS

Most optional features, such as Auto-Cut and Top Compression Platen are already programmed into the control & become operational when installed.

The fixed ratio UTS power pre-stretch system is available with constant tension spring dancer, and has incorporated a quick-threading cage. Simply open the cage, pull the film across the front of the unit and close the cage. The film is automatically threaded around the urethane stretch rollers, idler rollers and dancer. A plexiglass safety shield protects the operator from rotating rollers. Stretch ratios of 200%, 225%, 250% and 300% are available with the UTS film delivery.

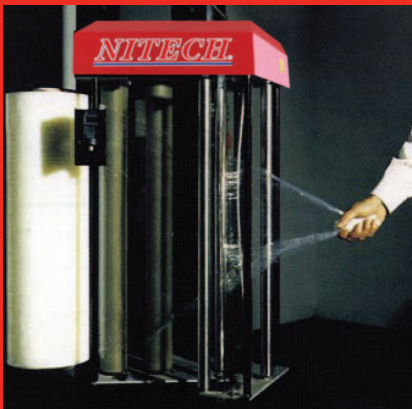

Quick threading feature
Pull-out cage enables film to be pulled across rollers easily.

When cage is closed, film is automatically positioned around stretch rollers and dancer roller.

- Accepts 20" and 30" Rolls of stretch film on 3" Core
- No-Thread Film Carriage
- 1/2 HP DC 90 Volt Motor
- Film Force Dial

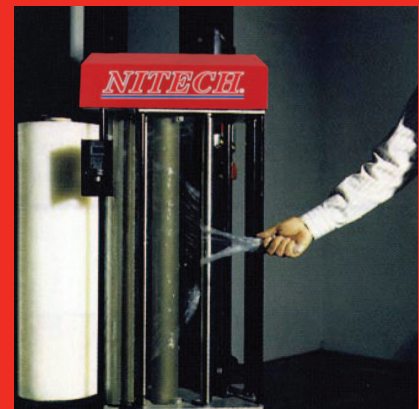

FEATURES

TOSHIBA PLC MICRO-COMPUTER

The 24 volt micro-computer control enables the operator to program and store up to 11 sequence programs. Touch key programming is simple and easy with instructions displayed on a 4 line LCD. The operator may select from three basic wrapping sequences with each sequence having three sets of values for the number of top and bottom wraps. In addition to these 9 sequence-programs, two additional programs include automatic belly-banding. The level at which belly-banding occurs and the number of belly-band wraps may be preset. Manual belly-banding may be activated by pressing and holding the start button while the elevator is traveling either up or down.

Status lights show POWER ON, READY & TENSION. Operating controls include START/RESUME, CONTROL ON/PAUSE, and STOP. The PAUSE and RESUME buttons enable the operator to stop the wrapper momentarily to place a top sheet or label on the load. Wrapper will also go into PAUSE mode if film breaks and operation may resume after film is attached.

4-YEAR WARRANTY

Confident in the ruggedness and proven maintenance-free features of this wrapper NITECH offers a 4-year all parts warranty on the model 20/20. The warranty is not only on parts made by NITECH but also on all parts used in NITECH equipment. All 20/20 models also have a 5 year structural warranty. We recognize our responsibility to supply quality parts to our customers and to warranty them whether made by NITECH or our suppliers.

A major achievement in the design of this series is that it is virtually maintenance free. No lubrication is required for 4 years. The 20/20 utilizes long life proximity sensors instead of limit switches. Controls operate on safe 24 volt DC power. Electronic components are modular plug-in and can be easily replaced if necessary. All motors are 90 volts DC. Higher efficiency drive systems reduce electrical power consumption and have higher starting torque.



LCD with menu and instructions for program and sequence selection. Touch key pad to select and store program options. Status lights indicate power, ready, and tension. Knobs to adjust turntable speed, film tension and elevator speed. Industrial push button controls for stop, control on/pause, start/resume and turntable jog.

STANDARD FEATURES

- Turntables are driven by non-stretch, non-jamming belt
- The table is supported by 8 lubricant free cam follower supports rated at 5,000lbs each
- Turntable powered by 3/4hp Helical DC gearmotor
- Variable speed 0-15rpm with soft start and soft stop
- 60" round turntable with 3" safety skirt
- 6,000 lb. (2700kgs) load capacity
- Lubrication free enclosed gear drive design
- Synthetic lube in all gearboxes (-30 to 120 degrees)
- Standard load diagonal = 80" (2032 mm)
With extended base = 128" (3251 mm)
- Standard load height = 80" (2032 mm)
With HI-SLIDE = 120/130" (3048 mm)
- Forklift portable from rear
- Up to 30" (762mm) film width
- Photo-electric load height sensor
- Micro computer control
- Cycle pause control
- Automatic & Manual belly banding
- 115 volts 50/60Hz 20 Amp service

OPTIONAL FEATURES

- Integrated scale
- Hi-slide telescoping mast for tall loads
- Auto-cut film at end of cycle
- Oversized turntables 65" and 72"
- Split or extended base
- Dual turntable
- Top compression platen for unstable loads
- Heater option for PLC operation in cold weather
Recommended use 32°F and below



Gasketed rear tower door swings open for access to the elevator and turntable gearmotor. The electrical control panel also swings open for easy access.



Model LP20/20 UTS DIMENSIONS

Max Load Height : 80" with 20" Film
90" with 30" Film
HI-SLIDE Load Height: 130"

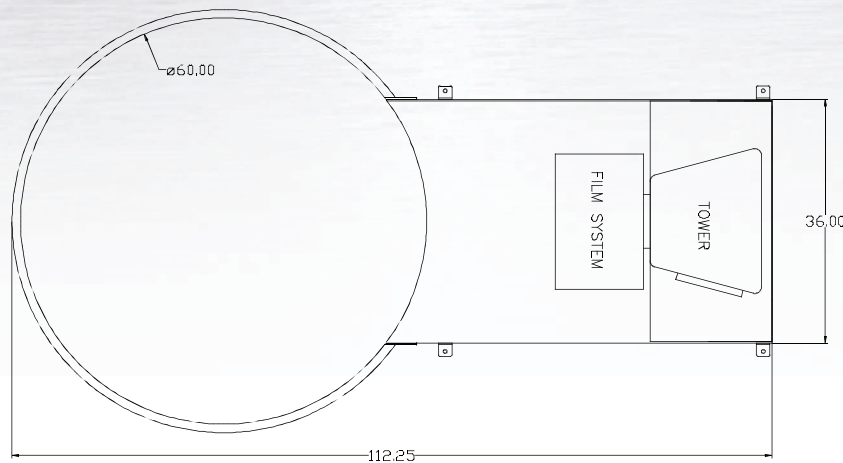
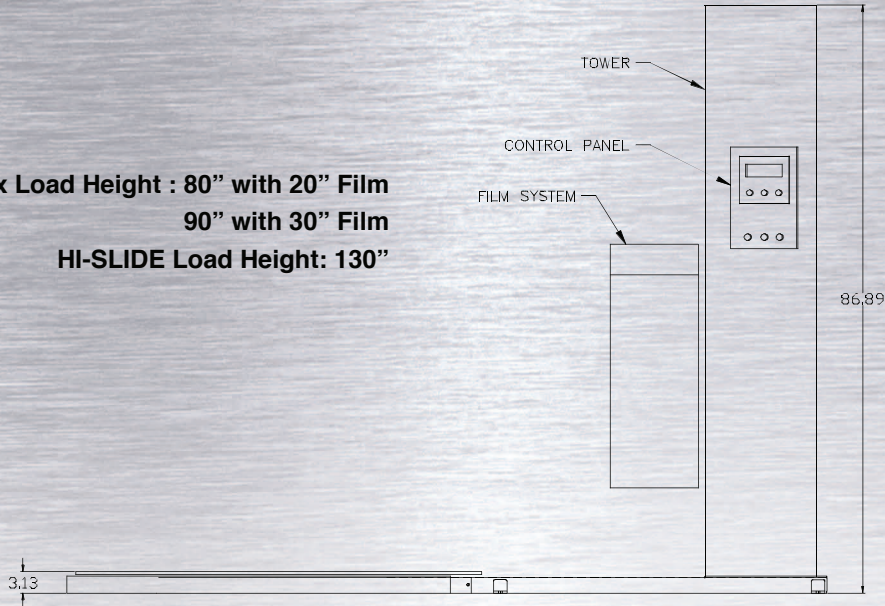

The following models are available in the 20/20 series:

High Profile Table

- LP 20/20 UTS
- LP 20/20 RBM
- DLP 20/20 UTS (Dual Turntable)
- DLP 20/20 PBM (Dual Turntable)

Film Tension System

- UTS Fixed Ratio Power Pre-Stretch
- Roller Brake - Magnetic Particle Brake
- UTS Fixed Ratio Power Pre-Stretch
- Roller Brake-Magnetic Particle Brake

Loading ramps may be placed on 3 sides of the turntable